

**TURCK**

**Industrial  
Automation**

**SAFETY  
MANUAL  
SWITCHING  
AMPLIFIERS**

IM1-12EX-R  
IM1-12EX-T  
IM1-12-T  
IM1-22EX-R  
IM1-22-R  
IM1-22EX-T  
IM1-121EX-R  
IM1-121EX-T  
MK13-R-EX0

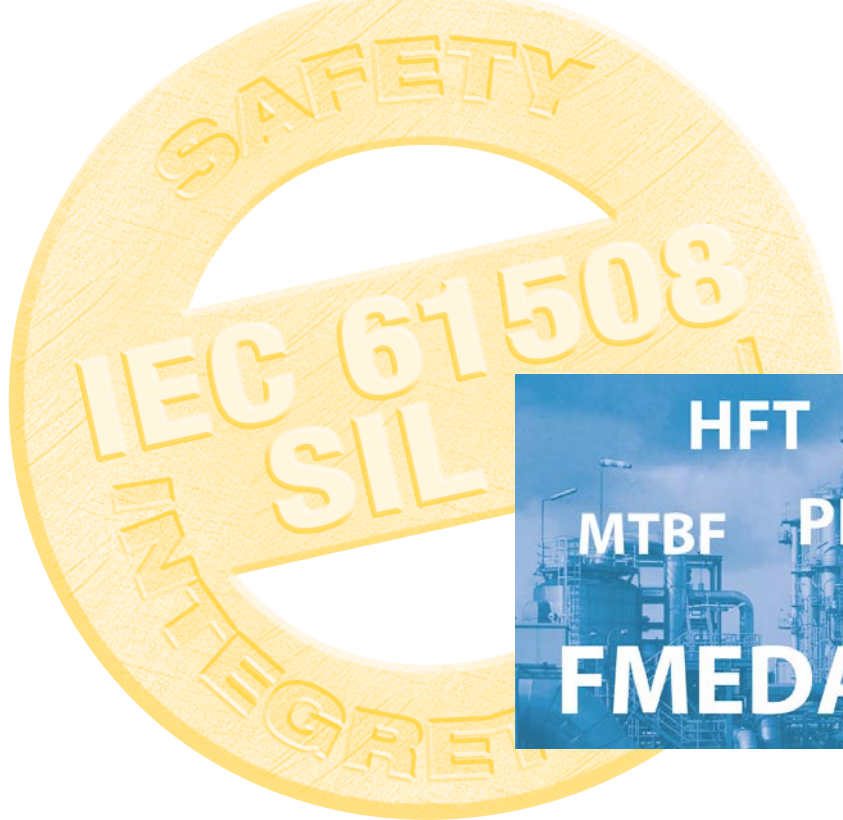

**HFT SFF  
MTBF PFD  
 $\lambda_{safe}$   
FMEDA**

***Sense it! Connect it! Bus it! Solve it!***

# Safety manual – switching amplifiers

<b>1</b>	<b>About this safety manual</b>	<b>5</b>
1.1	Target groups	5
1.2	Explanation of symbols	5
1.3	Abbreviations and terms	5
1.4	Document history	6
<b>2</b>	<b>Notes on devices</b>	<b>6</b>
2.1	Device variants	6
2.2	Manufacturer and Service	7
<b>3</b>	<b>For your safety</b>	<b>7</b>
3.1	Intended use	7
3.2	Obvious misuse	7
3.3	SIL registration card	7
3.4	General safety regulations	8
<b>4</b>	<b>Device specific information on safety applications</b>	<b>8</b>
4.1	Safety function	8
4.2	Safe state	8
4.3	Functions and operating modes	8
4.3.1	Signal change	9
4.3.2	Signal doubling	9
4.3.3	Line monitoring	9
4.3.4	Fault acknowledgement	9
4.4	Types of faults and failures	9
4.5	Safety characteristic values	9
4.5.1	FMEDA assumptions	9
4.5.2	Hardware architecture	9
4.5.3	Characteristic values for isolating switching amplifier MK13-R-Ex0	10
4.5.4	Characteristic values for IM1-...Ex-R	10
4.5.5	Characteristic values for IM1-...-Ex-T	10
4.6	Recurrent function tests	11
4.7	Useful life	11
4.8	Special regulations and restrictions	11
<b>5</b>	<b>Installation and commissioning</b>	<b>11</b>
5.1	Mounting	11
5.2	Connection	11
5.2.1	Wiring diagrams	12
5.3	Commissioning	16
5.3.1	Selecting sensors	16
5.3.2	Selecting mechanical contacts	16
5.4	Parameterization	16
<b>6</b>	<b>Operation, maintenance and repair</b>	<b>17</b>
6.1	Troubleshooting	17
6.2	Maintenance	17
6.3	Repair	18
6.3.1	Returning devices	18

# Safety manual – switching amplifiers

# Inhalt

<b>7</b>	<b>Decommissioning and withdrawal from service</b>	<b>18</b>
7.1	Decommissioning	18
7.2	Withdrawing from service	18
<b>8</b>	<b>Appendix – EXIDA FMEDA report Turck 04/07-14 R002</b>	<b>19</b>

## 1 About this safety manual

This safety manual contains instructions on the use of devices in safety instrumented systems (SIS). The consideration of safety-related values is based on IEC 61508. The safety manual describes the values determined for the SIL assessment and is only applicable in conjunction with the attached EXIDA FMEDA report Turck 04/07-14 R002. Read this document carefully before using the device. This will prevent the risk of personal injury or damage to property or equipment. Keep this manual safe during the service life of the device. If the device is passed on, hand over this safety manual as well.



### **DANGER**

Malfunction caused by operating errors

#### **Danger to life if safety function fails!**

- ▶ Observe the instructions contained in this safety manual without fail if the device is to be used in safety-related applications.

### 1.1 Target groups

This safety manual is designed for use by suitably qualified or trained personnel. It must be read and understood by anyone entrusted with any of the following tasks:

- Unpacking and mounting
- Commissioning
- Testing and maintenance
- Troubleshooting
- Disassembly and disposal

### 1.2 Explanation of symbols

The following symbols are used in this safety manual:



### **DANGER**

DANGER indicates an immediate hazardous situation that, if not avoided, will result in death or serious injury.



### **NOTE**

NOTE indicates tips, recommendations and important information. The notes contain information, particular operating steps that facilitate work and possibly help to avoid additional work resulting from incorrect procedures.

### ▶ **MANDATORY ACTION**

This symbol denotes actions that the user must carry out.

### ➡ **RESULT OF ACTION**

This symbol denotes the relevant results of actions and procedures.

### 1.3 Abbreviations and terms

Definition of terms, see IEC 61508-4

DC	diagnostic coverage
E/E/PE system	electrical/electronic/programmable electronic system
EUC	equipment under control
	dangerous failure
	no effect failure
	no part failure
	safe failure
	safe state
HFT	hardware fault tolerance

# Safety manual – switching amplifiers

	high demand mode	
	low demand mode	
<b>MooN</b>	M out of N channel architecture	
<b>MTBF</b>	mean time between failures	
<b>MTTR</b>	mean time to restoration	
<b>PFD</b>	probability of dangerous failure on demand	
<b>PFD<sub>AVG</sub></b>	average probability of dangerous failure on demand)	
<b>PFH</b>	average frequency of a dangerous failure per hour	
<b>SFF</b>	safe failure fraction	
<b>SIF</b>	safety instrumented function	Safety function
<b>SIS</b>	safety instrumented system	
<b>SIL</b>	safety integrity level	
	proof test	
	proof test interval	

## 1.4 Document history

<b>Rev.</b>	<b>Description</b>	<b>Date</b>
1.0.0	First edition	28.11.2014

The German version shall be considered the definitive document. Every care was taken in the production of the translations of this document. If there is any uncertainty in its interpretation, refer to the German version of the safety manual or contact TURCK directly.



### **NOTE**

In all cases use the latest version of this safety manual. Check whether a newer version is available.

## 2 Notes on devices

### 2.1 Device variants

This safety manual applies to the following TURCK isolating switching amplifiers:

IM1-12Ex-R	IM1-22Ex-T
IM1-12Ex-T	IM1-121Ex-R
IM1-12-T	IM1-121Ex-T
IM1-22Ex-R	MK13-R-Ex0
IM1-22-R	

### **Scope of delivery**

The device is supplied with the SIL registration card.

## 2.2 Manufacturer and Service

TURCK supports you in your projects – from the initial analysis right through to the commissioning of your application. The TURCK product database offers you several software tools for programming, configuring or commissioning, as well as data sheets and CAD files in many export formats. You can access the Product Database directly via the following address: [www.turck.de/produkte](http://www.turck.de/produkte)

For further inquiries in Germany contact the Sales and Service Team on:

Sales: +49 208 4952-380

Technical: +49 208 4952-390

For overseas inquiries contact your national TURCK representative.

Hans Turck GmbH & Co. KG  
45466 Mülheim an der Ruhr  
Germany

## 3 For your safety

The device is designed according to the latest state-of-the-art technology. Residual hazards, however, still exist. Observe the following warnings and safety regulations in order to prevent danger to persons and property. TURCK accepts no liability for damage caused by failure to observe regulations.

### 3.1 Intended use

The isolating switching amplifiers are used for the galvanically isolated transmission of binary signals from sensors and mechanical contacts. Sensors acc. to EN 60947-5-6 (NAMUR) or mechanical contacts can be connected.

The output circuits are isolated from the input circuits and are either designed as relay outputs or potentially isolated transistor outputs.

The IM1-...Ex-... and MK13-R-Ex0 isolating switching amplifiers have Ex approval and are used for transmitting binary signals from the Ex area to the safe area.

These devices also enable the creation of safety-related systems up to and including SIL2 according to IEC 61508 (hardware fault tolerance HFT = 0). The devices must only be used in safety-related systems if all requirements stated in this safety manual and the EXIDA report are strictly observed. The information in the EXIDA report applies when IEC 61508 is used for applications with a low demand mode (device type A for low demand mode). When used in safety systems, the probability of dangerous failure (PFD) for the entire circuit must be determined and given due consideration.

### 3.2 Obvious misuse

When using dual-channel devices in safety circuits, the second channel must not be used to increase the hardware fault tolerance and thus achieve a higher SIL level.

The IM1-...Ex-... isolating switching amplifiers may be installed in zone 2 in accordance with the ATEX Directive; The IM1-...-... and MK13-R-Ex0 isolating switching amplifiers must not be installed in explosion hazardous areas in accordance with the ATEX Directive.

### 3.3 SIL registration card



#### NOTE

With safety-related applications, the SIL registration card enclosed with the device must be filled in completely by the user and returned to TURCK without fail.

# Safety manual – switching amplifiers

## 3.4 General safety regulations

- It is the responsibility of the user to ensure that the device is used in compliance with the applicable regulations, standards and laws.
- The suitability for specific applications must be assessed by considering the particular overall safety-related system with regard to the requirements of IEC 61508.
- The device must only be carried out by trained and qualified personnel.
- The device must only be commissioned and operated by trained and qualified personnel.
- A function test must be completed prior to initial operation, after each parameter setting, after repair and replacement, as well as at the stipulated interval T[Proof]
- When the device is in operation, ensure that the power supply is within the specified voltage range.
- Ensure that the plug connections and cables are always in good condition.
- A check must be made whether the required function was set on the device before it is used in the safety-related circuit.
- Special application-specific factors such as chemical and physical stresses may cause the premature wear of the devices and must be taken into consideration when planning systems; take special measures to compensate for a lack of experience based values, e.g. through the implementation of shorter test intervals.
- If faults occur in the device that cause a switch to the defined safe state, measures must be taken to maintain the safe state during the further operation of the overall control system.
- TURCK must be notified of dangerous failures immediately.
- A faulty device must be replaced immediately and must not be repaired.
- The device must be replaced immediately if the terminals are faulty or the device has any visible faults.
- Interventions and conversions on the device are not permissible. Repairs must only be carried out by TURCK. Return the device to TURCK for this (see section "Repair").
- The device must be protected from accidental modification of the settings.

## 4 Device specific information on safety applications

### 4.1 Safety function

Input signal evaluation:

- Depending on the input signal and the operating mode,
  - the relay is de-energized (device with relay output)
  - the transistor is blocked (device with transistor output)
- The wire-break monitoring and short circuit monitoring are part of the safety function. Wire breaks and short circuits each cause the LOW output signal.



#### **DANGER**

The characteristic values determined apply to the use of an output in safety-related functions. The second output must not be used for the safety function with signal doubling.

#### **Danger to life due to misuse!**

- Only use one output for the safety function with signal doubling.
- 

### 4.2 Safe state

The safe state is defined as the state when the output is LOW (relay dropped out or transistor blocked).

### 4.3 Functions and operating modes

Isolating switching amplifiers with a NAMUR input have the following features:

- Switch point:  $(1.55 \pm 0.2)$  mA
- Current consumption on wire break:  $< 0.2$  mA
- Current consumption on short circuit:  $> 6$  mA



## 4.3.1 Signal change

Signal change on 2-channel devices: A signal change at the input causes a signal change at the corresponding output.

## 4.3.2 Signal doubling

Signal doubling: A signal change at the input of channel 1 causes a signal change at both outputs.

## 4.3.3 Line monitoring

In the event of a wire break or short circuit, the associated output switches to LOW.

## 4.3.4 Fault acknowledgement

Faults do not have to be acknowledged. If the fault is rectified, the device automatically resumes operation.

## 4.4 Types of faults and failures

Failures must be classified in conjunction with the application into safe (non-hazardous) and unsafe (hazardous) failures. You as the operator are responsible for this.



### NOTE

TURCK must be notified immediately of all damage that was caused by a dangerous undetected failure.

## 4.5 Safety characteristic values

### 4.5.1 FMEDA assumptions

The safety-related characteristic values were determined based on an FMEDA in accordance with IEC 61508. The FMEDA is based on the following assumptions:

- The failure rates are constant.
- The mechanical wear is not considered.
- The propagation of failures is not relevant.
- The MTTR repair time after a safe failure is 8 hours (replacement of the device).
- The device is operated in low demand mode.
- The failure rates of an external power supply are not considered.
- Only one input and one output are part of the safety function.
- The failure rates used are the Siemens standards SN 29500 at 40 °C .
- The second channel of a device cannot be used to increase the HFT hardware fault tolerance.
- The ambient conditions correspond to an average industrial environment, as defined in MIL-HNBK-217-F or IEC 60654-1, Class C (sheltered location).
  - The ambient temperature is normally 40 °C.
  - A safety factor of 2.5 must be applied for ambient temperatures of 60 °C and frequent temperature fluctuations.

### 4.5.2 Hardware architecture

The device is considered as a Type A component (non complex). The hardware fault tolerance HFT is 0.

# Safety manual – switching amplifiers

## 4.5.3 Characteristic values for isolating switching amplifier MK13-R-Ex0

The device can be used for applications up to SIL 2.

$$MTBF = MTTF + MTTR = 1/(\lambda_{total} + \lambda_{not\ part}) + 8\ h = 279\ years$$

### MK13-R-Ex0 – Rate of safe and dangerous failures

$\lambda_{safe}$	$\lambda_{dangerous}$	SFF
288 FIT	110 FIT	72.44%

### MK13-R-Ex0 – Average probability of failure on demand

T[Proof] = 1 year	T[Proof] = 5 years	T[Proof] = 10 years
PFD <sub>AVG</sub> = $4.80 \times 10^{-4}$	PFD <sub>AVG</sub> = $2.40 \times 10^{-3}$	PFD <sub>AVG</sub> = $4.79 \times 10^{-3}$

## 4.5.4 Characteristic values for IM1-...Ex-R

The devices can be used for applications up to SIL 2.

$$MTBF = MTTF + MTTR = 1/(\lambda_{total} + \lambda_{not\ part}) + 8\ h = 272\ years$$

### IM1-...Ex-R – Rate of safe and dangerous failures

$\lambda_{safe}$	$\lambda_{dangerous}$	SFF
299 FIT	110 FIT	73.15%

### IM1-...Ex-R – Average probability of failure on demand

T[Proof] = 1 year	T[Proof] = 5 years	T[Proof] = 10 years
PFD <sub>AVG</sub> = $4.80 \times 10^{-4}$	PFD <sub>AVG</sub> = $2.40 \times 10^{-3}$	PFD <sub>AVG</sub> = $4.79 \times 10^{-3}$

## 4.5.5 Characteristic values for IM1-...-Ex-T

The devices can be used for applications up to SIL 2.

$$MTBF = MTTF + MTTR = 1/(\lambda_{total} + \lambda_{not\ part}) + 8\ h = 314\ years$$

### IM1-...-Ex-T – Rate of safe and dangerous failures

$\lambda_{safe}$	$\lambda_{dangerous}$	SFF
267 FIT	85 FIT	75.89%

### IM1-...-Ex-T – Average probability of failure on demand

T[Proof] = 1 year	T[Proof] = 5 years	T[Proof] = 10 years
PFD <sub>AVG</sub> = $3.72 \times 10^{-4}$	PFD <sub>AVG</sub> = $1.86 \times 10^{-3}$	PFD <sub>AVG</sub> = $3.71 \times 10^{-3}$



### NOTE

The PFD<sub>AVG</sub> value of the isolating switching amplifier should be designed to be max. 10 % of the total permissible PFD<sub>AVG</sub> value for the safety integrity level SIL2. A PFD<sub>AVG</sub> value marked in green means that the PFD value is within the range of SIL2 in accordance with IEC 61508-1 and is less than 10 % of the total value for SIL2. A PFD<sub>AVG</sub> value marked in yellow indicates that the PFD value is within the range of SIL2 in accordance with IEC 61508-1 but is more than 10 % of the total value for SIL2.

## 4.6 Recurrent function tests

A function test must be completed prior to initial operation, after each parameter setting, after repair and replacement, as well as at the stipulated interval T[Proof]:

- Ensure that the function test is only carried out by qualified personnel.
- Think first about your safety and the safety of your environment. If in doubt, replace the device.
- Bridge the isolating switching amplifier in the safety controller (process control system) and ensure that safety is maintained. You as the operator are responsible for ensuring that safety is maintained.
- At the input simulate a short circuit and check whether the outputs switch to LOW.
- At the input simulate a wire break and check whether the outputs switch to LOW.
- At the input simulate a switch operation and check whether the corresponding output behaves as per the required setting.
- If all checks have been completed and no faults found, restart the safety circuit.
- Once the test has been completed, document and archive the results.



### NOTE

The function test detects more than 90 % of the undetected dangerous failures (Du) of the device

## 4.7 Useful life

The calculated failure rates of the device are valid for a useful lifetime of 8 years.

## 4.8 Special regulations and restrictions



### NOTE

Each application has its particular conditions of use and ambient requirements. For this reason, the safety-related assessment of a system must always take the actual process into account – in addition to the general statements concerning probability of failure, tolerances and failure rates of the components. Special application-specific factors such as chemical and physical stresses may thus cause the premature wear of the devices and must therefore be taken into consideration when planning systems. Take special measures to compensate for a lack of experience based values, e.g. through the implementation of shorter test intervals. The assessment of the diagnostic coverage (DC) can vary from application to application. The assessment of the hardware fault tolerance (HFT) can only be made if restrictions on the use of the compliant object are made.

# 5 Installation and commissioning



### DANGER

Failure caused by commissioning and operating errors

**Danger to life if safety function fails!**

- Ensure that the product is only fitted, installed, operated and maintained by trained and qualified personnel.

## 5.1 Mounting

Observe the mounting instructions in the user manual.

## 5.2 Connection

Observe the mounting instructions in the user manual.

# Safety manual – switching amplifiers

## 5.2.1 Wiring diagrams

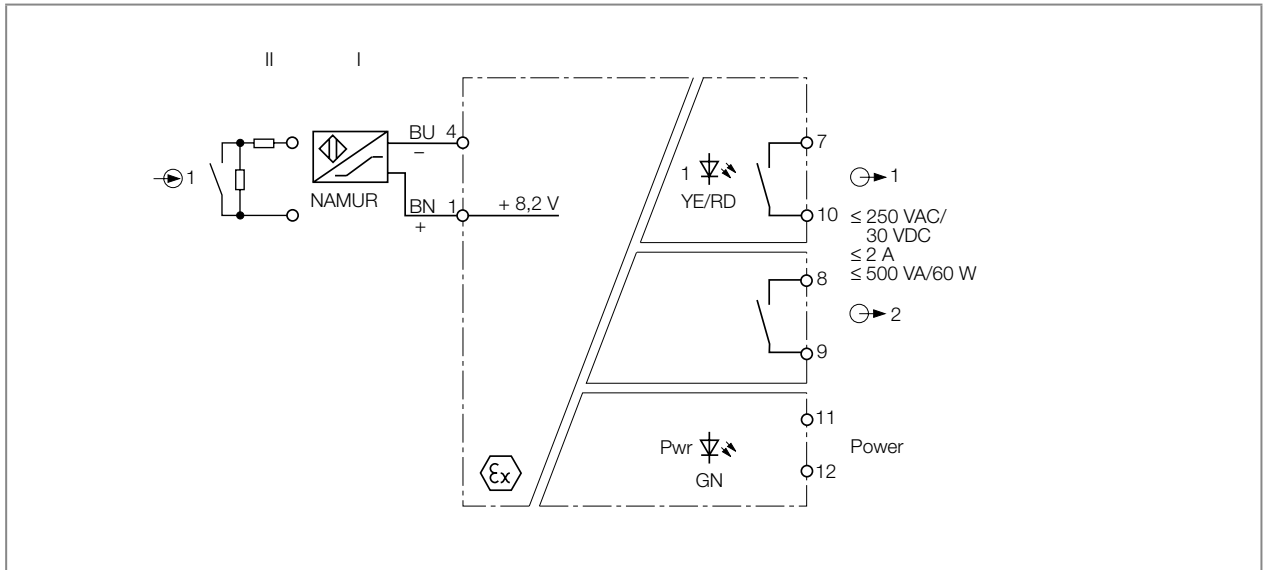

Fig. 1: Block diagram of the IM1-12Ex-R

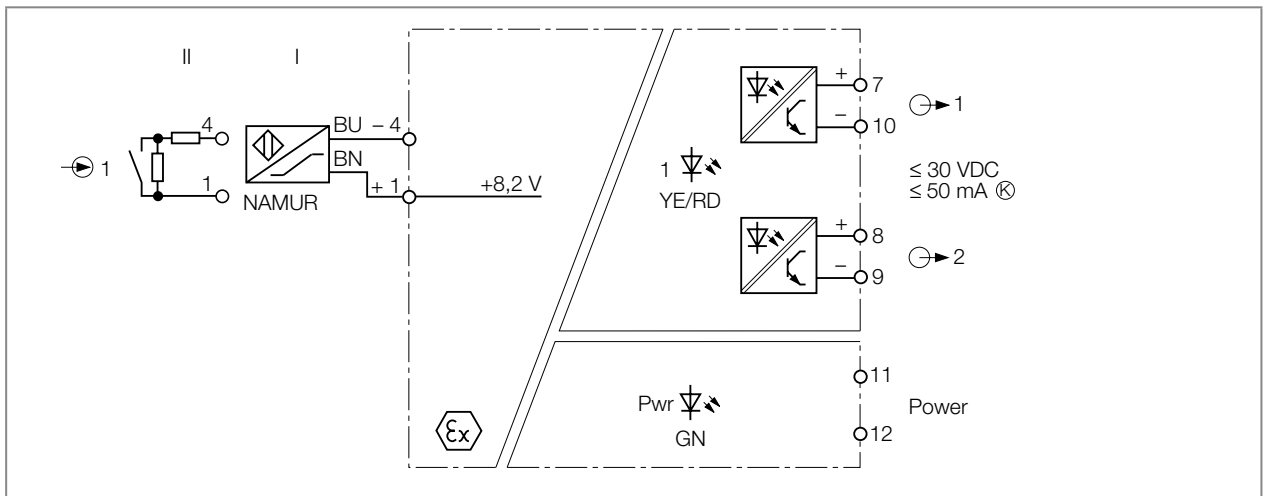

Fig. 2: Block diagram of the IM1-12Ex-T

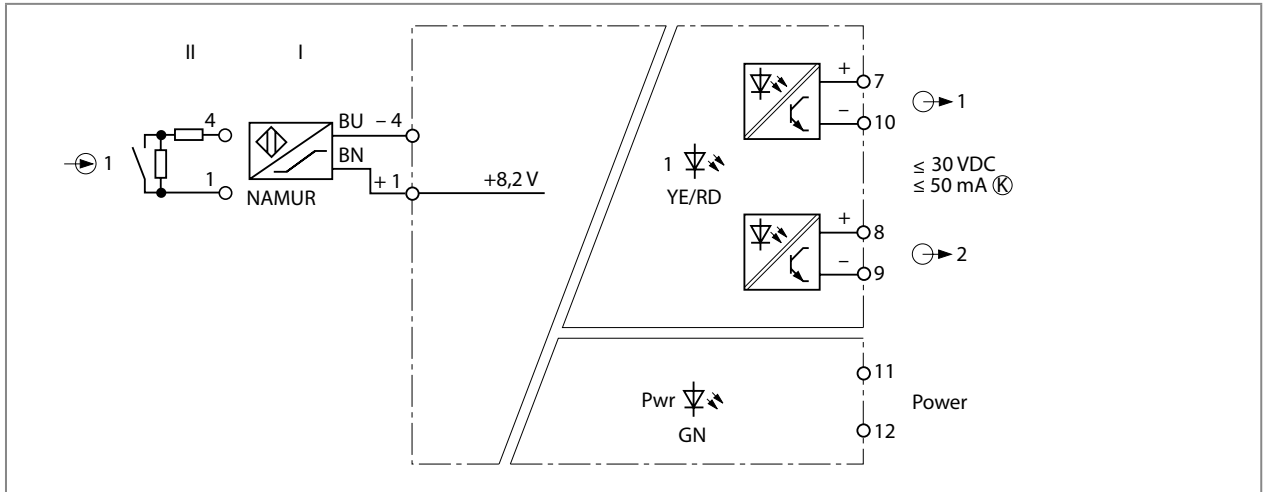

Fig. 3: Block diagram of the IM1-12-T

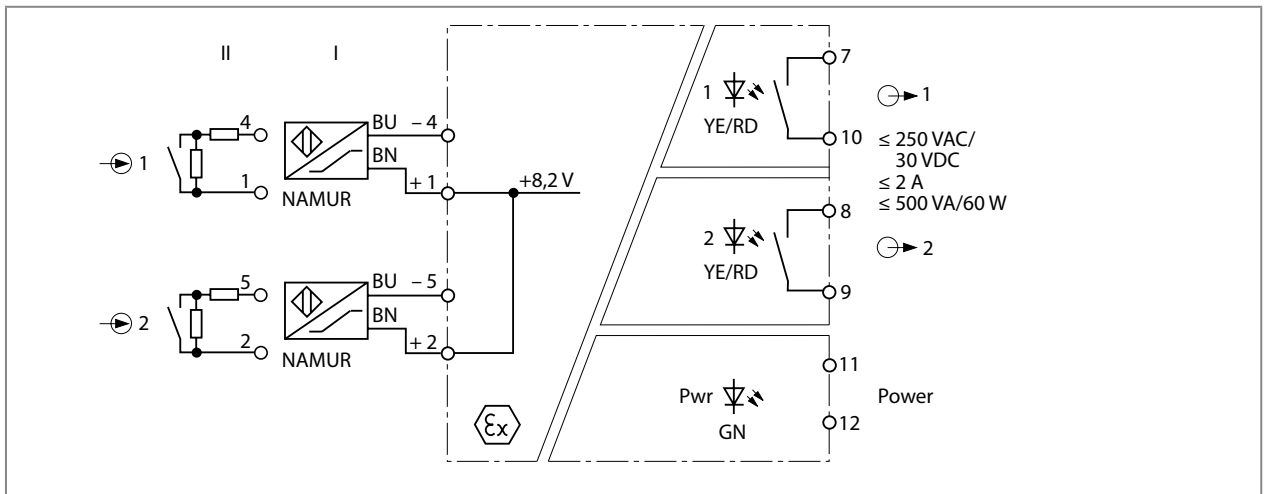

Fig. 4: Block diagram of the IM1-22Ex-R

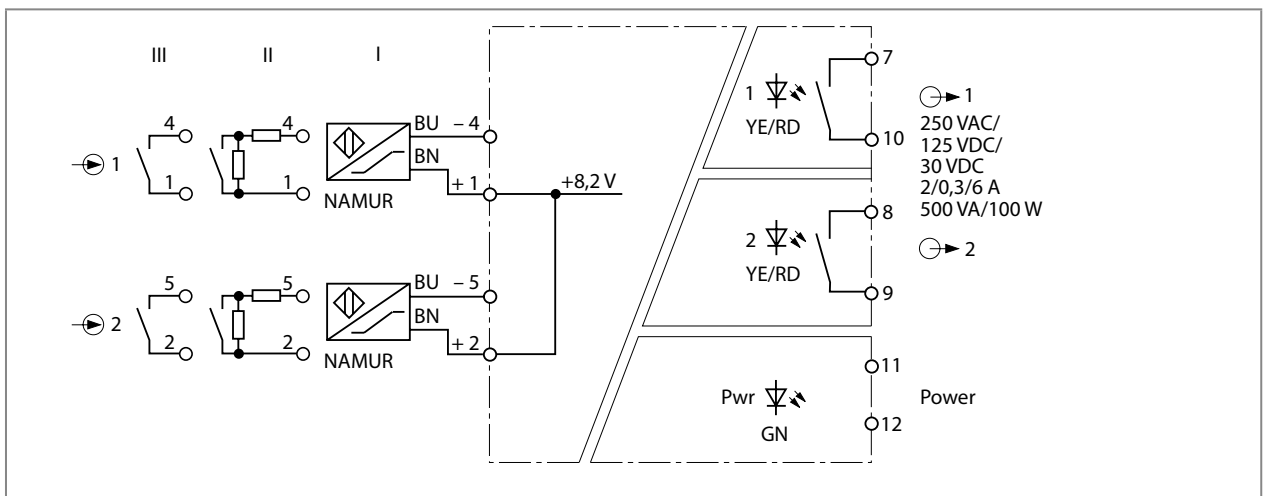

Fig. 5: Block diagram of the IM1-22-R

# Safety manual – switching amplifiers

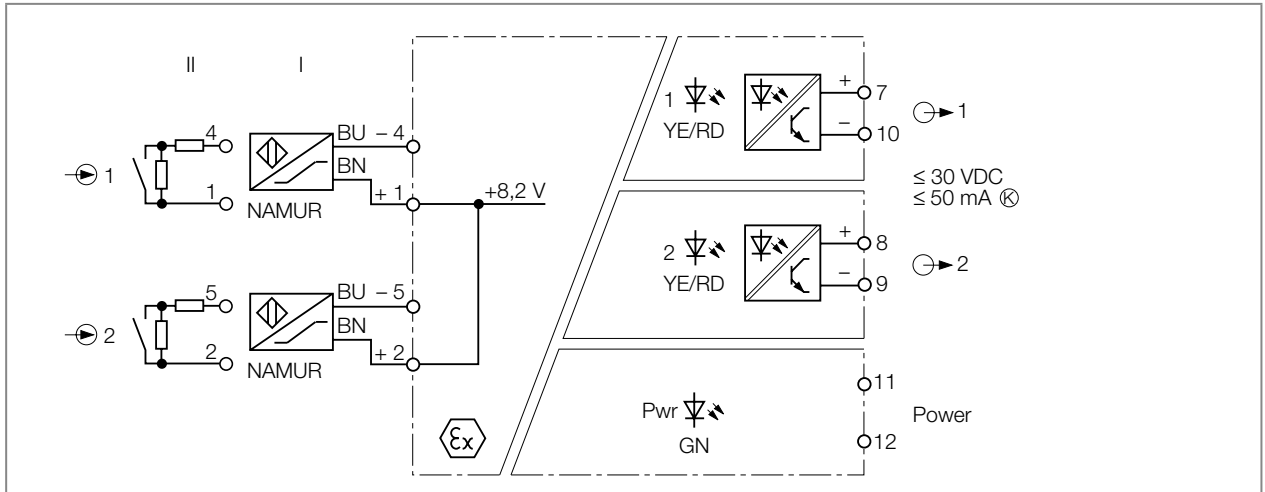

Fig. 6: Block diagram of the IM1-22Ex-T

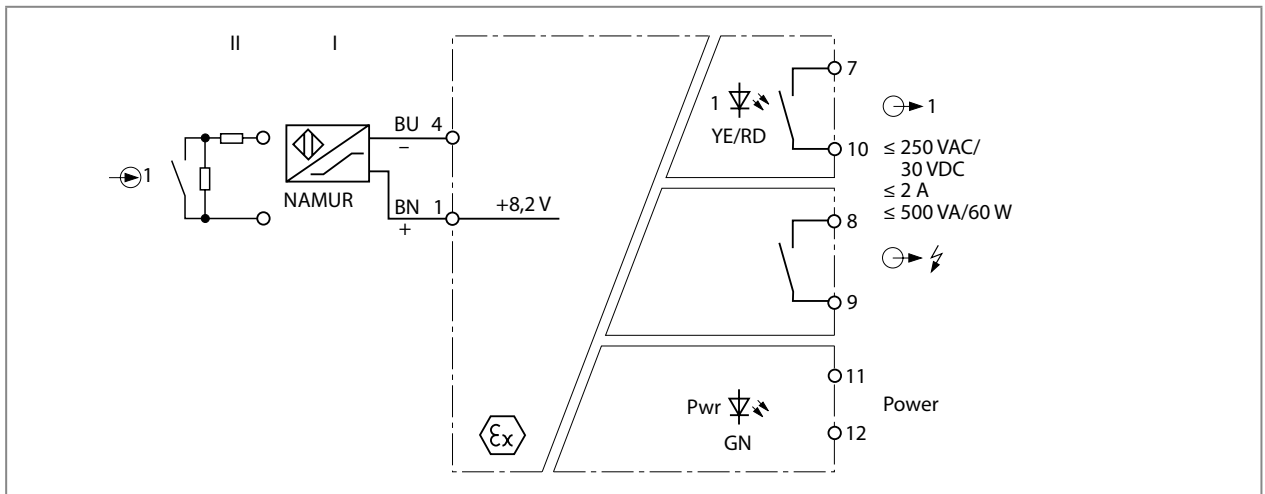

Fig. 7: Block diagram of the IM1-121Ex-R

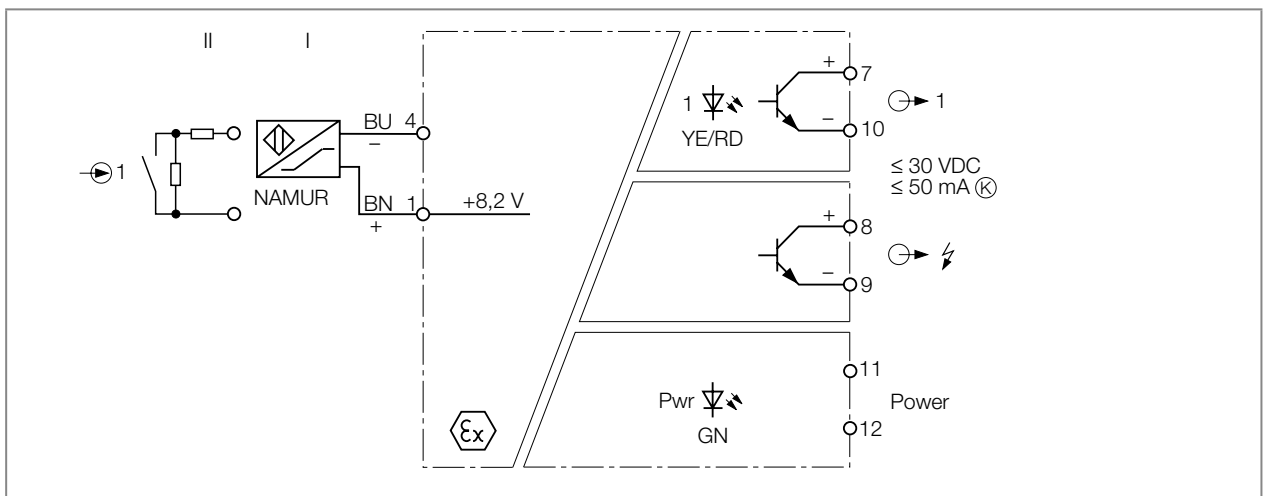

Fig. 8: Block diagram of the IM1-121-Ex-T

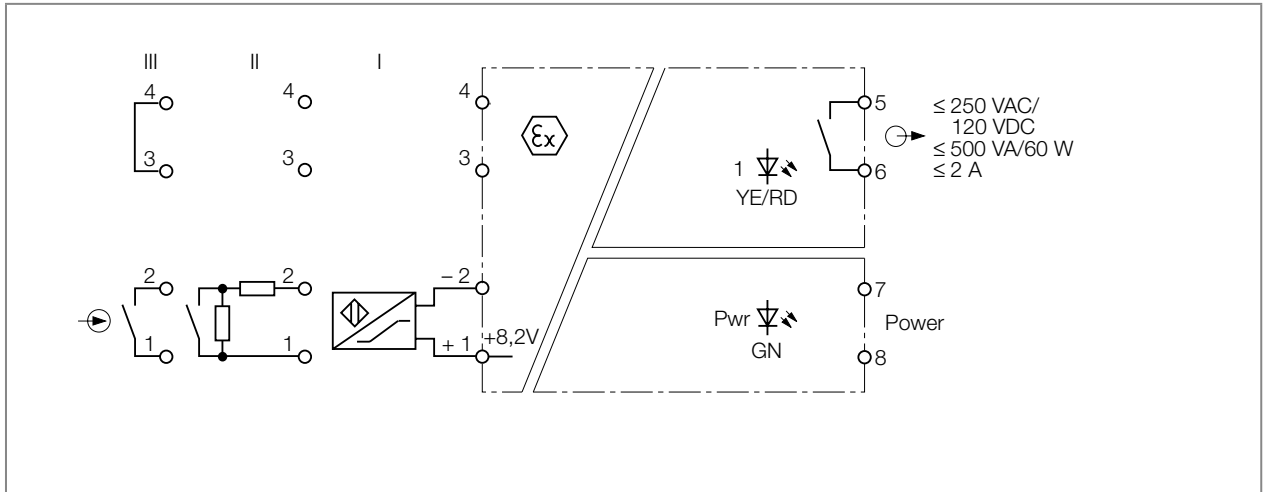

Fig. 9: Block diagram of the MK13-R-Ex0

# Safety manual – switching amplifiers

## 5.3 Commissioning

When the device is in operation, ensure that the power supply is within the specified voltage range. Commissioning is described in the operating instructions for the particular device.



### DANGER

Malfunction caused by operating errors

#### Danger to life if safety function fails!

- A function test must be completed prior to initial operation, after each parameter setting, after repair and replacement, as well as at the stipulated interval T[Proof].

### 5.3.1 Selecting sensors

If sensors are used in safety circuits in accordance with EN 60947-5-6:2000, the sensors must be certified according to IEC 61508.

Ensure that the devices and the housing materials are suitable for the application.

For this refer also to the applicable data sheets of the TURCK devices at [www.turck.com](http://www.turck.com).

### 5.3.2 Selecting mechanical contacts

If mechanical contacts are used in safety circuits, they must be certified according to IEC 61508.

## 5.4 Parameterization



### DANGER

Malfunction caused by operating errors

#### Danger to life if safety function fails!

- A function test must be completed prior to initial operation, after each parameter setting, after repair and replacement, as well as at the stipulated interval T[Proof].



### DANGER

Accidental changing of parameters

#### Danger to life if safety function fails!

- Protect the device from accidental adjustment.

The DIP switches on the front can be used to set the output mode of the switching output and activate an input circuit and short circuit monitoring for each channel.

Switch	Meaning
NO	Normally open operation
NC	Normally closed operation
WB	Wire break monitoring activated
SC	Short circuit monitoring activated
LM	Line monitoring for wire break and short circuit (only MK13-R-Ex0)
off	corresponding function deactivated

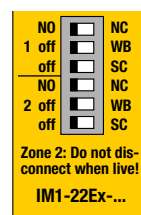
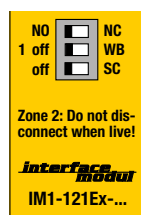
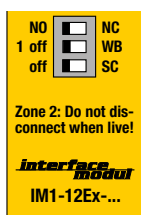

Fig. 10: Setting via DIP switch



The following function table shows different input states with the corresponding output states. Bear in mind that the switching behavior of inductive sensors as per EN 60947-5-6 (NAMUR) correspond to that of mechanical NO contacts. The switching behavior of capacitive and magnetic inductive sensors is the same as that of NO contacts.

Wirkungsrichtung Function mode Sens d'action	Eingang/input/entrée		Ausgang/output/sortie			
	Induktiver Sensor inductive sensor détecteur inductif EN 60947-5-6 NAMUR	mechanischer Kontakt dry contact contact mécanique R1 = 1...2,2 kΩ (> ¼ W) R2 = 10...22 kΩ (> ¼ W)	kein Fehler/normal/sans défaut	IM1-121Ex-... Störmeldeausgang alarm output sortie de sig. de défaut	mit Fehler/short or wire-break/avec défaut	IM1-121Ex-... Störmeldeausgang alarm output sortie de sig. de défaut
Arbeitsstromverhalten load current mode (N.O.) fonction travail  <b>NO</b>			0	1	0	0
			1	1	0	0
Ruhestromverhalten no load current mode (N.C.) fonction repos  <b>NC</b>			1	1	0	0
			0	1	0	0

Fig. 11: Function table

## 6 Operation, maintenance and repair

The information is valid for the operating stress conditions in an industrial environment as per IEC 606541-1 Class C (sheltered location) with an ambient temperature of 40 °C over a long period of time.

### 6.1 Troubleshooting

The rectification of faults is described in the operating instructions for the particular device.



#### NOTE

The user must notify TURCK immediately of any faults on the device which occur when it is used in safety instrumented applications.

### 6.2 Maintenance

Ensure that the plug connections and cables are always in good condition.  
The devices are maintenance-free, clean dry if required.



#### DANGER

Malfunction caused by conductive media or static charge

**Danger to life if safety function fails!**

➤ When cleaning do not use any liquid media or statically charging cleaning agent.



#### DANGER

Accidental changing of parameters

**Danger to life if safety function fails!**

➤ Perform a function test after each cleaning.

# Safety manual – switching amplifiers

## 6.3 Repair

---



### **DANGER**

The device must not be repaired.

**Danger to life due to malfunction!**

► Send the device to TURCK for repair. Observe here the specific warranty conditions agreed with the shipment.

---

### 6.3.1 Returning devices

If a device has to be returned, bear in mind that only devices with a decontamination declaration will be accepted. This is available for download at [http://www.turck.de/static/media/downloads/Dekontamination\\_en.pdf](http://www.turck.de/static/media/downloads/Dekontamination_en.pdf) and must be completely filled in, and affixed securely and weather-proof to the outside of the packaging.

## 7 Decommissioning and withdrawal from service

### 7.1 Decommissioning

Decommissioning is described in the operating instructions for the particular device.

### 7.2 Withdrawing from service

After the useful lifetime of eight years has expired, the devices must be taken out of service. These devices are designed for installation in fixed industrial installations and equipment, which must be disposed of in accordance with the laws and regulations applicable to these installations. They must not be included in normal household garbage.

8 Appendix – EXIDA FMEDA report Turck 04/07-14 R002



## Failure Modes, Effects and Diagnostic Analysis

Project:

Isolating Switching Amplifiers IM1-\*\*(Ex)-\* and MK13-R-Ex0

Customer:

Hans Turck GmbH & Co. KG  
Mühlheim  
Germany

Contract No.: TURCK 04/07-14

Report No.: TURCK 04/07-14 R002

Version V3, Revision R0, February 2014

Stephan Aschenbrenner

The document was prepared using best effort. The authors make no warranty of any kind and shall not be liable in any event for incidental or consequential damages in connection with the application of the document.

© All rights on the format of this technical report reserved.



## Management summary

This report summarizes the results of the hardware assessment carried out on the Isolating Switching Amplifiers IM1-\*\*(Ex)-\* and MK13-R-Ex0.

Table 1 gives an overview of the different versions that belong to the considered devices.

The hardware assessment consists of a Failure Modes, Effects and Diagnostics Analysis (FMEDA). A FMEDA is one of the steps taken to achieve functional safety assessment of a device per IEC 61508. From the FMEDA, failure rates are determined and consequently the Safe Failure Fraction (SFF) is calculated for the device. For full assessment purposes all requirements of IEC 61508 must be considered.

**Table 1: Version overview**

Type	Description <sup>1</sup>	Parts List / Circuit Diagram
IM1-12Ex-R IM1-12-R	1 input / 2 relay outputs	12296307 of 07.10.04 / 12296307 of 28.09.04
IM1-12Ex-T IM1-12-T	1 input / 2 transistor outputs	12296309 of 07.10.04 / 12296309 of 28.09.04
IM1-22Ex-R IM1-22-R	2 inputs / 2 relay outputs	12296301 of 07.10.04 / 12296301 of 28.09.04
IM1-22Ex-T IM1-22-T	2 inputs / 2 transistor outputs	12296303 of 13.08.04 / 12296303 of 28.09.04
IM1-121Ex-R	1 input / 2 relay outputs (one used as error message output)	12296310 of 07.10.04 / 12296310 of 28.09.04
IM1-121Ex-T	1 input / 2 transistor outputs (one used as error message output)	12296312 of 25.01.05 / 12296312 of 28.09.04
MK13-R-Ex0	1 input / 1 relay output	12296101 of 18.10.04 / 12296100 of 07.10.04

The failure rates used in this analysis are the basic failure rates from the Siemens standard SN 29500.

According to table 2 of IEC 61508-1 the average PFD for systems operating in low demand mode has to be  $\geq 10^{-3}$  to  $< 10^{-2}$  for SIL 2 safety functions. However, as the modules under consideration are only one part of an entire safety function they should not claim more than 10% of this range, i.e. they should be better than or equal to 1,00E-03.

The Isolating Switching Amplifiers IM1-\*\*(Ex)-\* and MK13-R-Ex0 are considered to be Type A<sup>2</sup> components with a hardware fault tolerance of 0.

For Type A components the SFF has to be 60% to  $< 90\%$  according to table 2 of IEC 61508-2 for SIL 2 (sub-) systems with a hardware fault tolerance of 0.

The following failure rates are valid for operating stress conditions typical of an industrial field environment similar to IEC 60654-1 class C (sheltered location) with an average temperature over a long period of time of 40°C. For a higher average temperature of 60°C, the failure rates should be multiplied with an experience based factor of 2,5. A similar multiplier should be used if frequent temperature fluctuation must be assumed.

<sup>1</sup> The two channels on a redundant board shall not be used to increase the hardware fault tolerance needed for a higher SIL as they contain common components.

<sup>2</sup> Type A component: “Non-complex” component (all failure modes are well defined); for details see 7.4.3.1.2 of IEC 61508-2.

Table 2: Summary for MK13-R-Ex0 – Failure rates

$\lambda_{\text{safe}}$	$\lambda_{\text{dangerous}}$	SFF
288 FIT	110 FIT	72%

Table 3: Summary for MK13-R-Ex0 – PFD<sub>AVG</sub> values

T[Proof] = 1 year	T[Proof] = 5 years	T[Proof] = 10 years
PFD <sub>AVG</sub> = 4,80E-04	PFD <sub>AVG</sub> = 2,40E-03	PFD <sub>AVG</sub> = 4,79E-03

Table 4: Summary for IM1-\*\*\*-R – Failure rates

$\lambda_{\text{safe}}$	$\lambda_{\text{dangerous}}$	SFF
299 FIT	110 FIT	73%

Table 5: Summary for IM1-\*\*\*-R – PFD<sub>AVG</sub> values

T[Proof] = 1 year	T[Proof] = 5 years	T[Proof] = 10 years
PFD <sub>AVG</sub> = 4,80E-04	PFD <sub>AVG</sub> = 2,40E-03	PFD <sub>AVG</sub> = 4,79E-03

Table 6: Summary for IM1-\*\*\*-T – Failure rates

$\lambda_{\text{safe}}$	$\lambda_{\text{dangerous}}$	SFF
267 FIT	85 FIT	75%

Table 7: Summary for IM1-\*\*\*-T – PFD<sub>AVG</sub> values

T[Proof] = 1 year	T[Proof] = 5 years	T[Proof] = 10 years
PFD <sub>AVG</sub> = 3,72E-04	PFD <sub>AVG</sub> = 1,86E-03	PFD <sub>AVG</sub> = 3,71E-03

The boxes marked in yellow (   ) mean that the calculated PFD<sub>AVG</sub> values are within the allowed range for SIL 2 according to table 2 of IEC 61508-1 but do not fulfill the requirement to not claim more than 10% of this range, i.e. to be better than or equal to 1,00E-03. The boxes marked in green (   ) mean that the calculated PFD<sub>AVG</sub> values are within the allowed range for SIL 2 according to table 2 of IEC 61508-1 and table 3.1 of ANSI/ISA–84.01–1996 and do fulfill the requirement to not claim more than 10% of this range, i.e. to be better than or equal to 1,00E-03.

Because the Safe Failure Fraction (SFF) is above 60%, also the architectural constraints requirements of table 2 of IEC 61508-2 for Type A subsystems with a Hardware Fault Tolerance (HFT) of 0 are fulfilled.

A user of the Isolating Switching Amplifiers IM1-\*\*(Ex)-\* and MK13-R-Ex0 can utilize these failure rates in a probabilistic model of a safety instrumented function (SIF) to determine suitability in part for safety instrumented system (SIS) usage in a particular safety integrity level (SIL). A full table of failure rates is presented in sections 5.1 to 5.3 along with all assumptions.

The failure rates are valid for the useful life of the Isolating Switching Amplifiers IM1-\*\*(Ex)-\* and MK13-R-Ex0, which is estimated to be between 8 and 12 years (see Appendix 2).

It is important to realize that the “no effect” failures are included in the “safe undetected” failure category according to IEC 61508. Note that these failures on its own will not affect system reliability or safety, and should not be included in spurious trip calculations.



## Table of Contents

Management summary .....	2
1 Purpose and Scope .....	5
2 Project management.....	6
2.1 <i>exida.com</i> .....	6
2.2 Roles of the parties involved .....	6
2.3 Standards / Literature used.....	6
2.4 Reference documents .....	6
2.4.1 Documentation provided by the customer.....	6
2.4.2 Documentation generated by <i>exida.com</i> .....	7
3 Description of the analyzed modules .....	8
4 Failure Modes, Effects, and Diagnostic Analysis .....	10
4.1 Description of the failure categories .....	10
4.2 Methodology – FMEDA, Failure rates.....	10
4.2.1 FMEDA.....	10
4.2.2 Failure rates .....	11
4.2.3 Assumptions.....	11
5 Results of the assessment.....	12
5.1 Isolating Switching Amplifier MK13-R-Ex0.....	13
5.2 Isolating Switching Amplifier IM1-***-R.....	15
5.3 Isolating Switching Amplifier IM1-***-T .....	17
6 Terms and Definitions.....	19
7 Status of the document.....	20
7.1 Liability.....	20
7.2 Releases .....	20
7.3 Release Signatures.....	20
Appendix 1: Possibilities to reveal dangerous undetected faults during the proof test..	20
Appendix 1.1: Possible proof tests to detect dangerous undetected faults.....	24
Appendix 2: Impact of lifetime of critical components on the failure rate.....	25

## 1 Purpose and Scope

Generally three options exist when doing an assessment of sensors, interfaces and/or final elements.

### Option 1: Hardware assessment according to IEC 61508

Option 1 is a hardware assessment by *exida.com* according to the relevant functional safety standard(s) like DIN V VDE 0801, IEC 61508 or EN 954-1. The hardware assessment consists of a FMEDA to determine the fault behavior and the failure rates of the device, which are then used to calculate the Safe Failure Fraction (SFF) and the average Probability of Failure on Demand (PFD<sub>AVG</sub>).

This option for pre-existing hardware devices shall provide the safety instrumentation engineer with the required failure data as per IEC 61508 / IEC 61511 and does not include an assessment of the software development process

### Option 2: Hardware assessment with proven-in-use consideration according to IEC 61508 / IEC 61511

Option 2 is an assessment by *exida.com* according to the relevant functional safety standard(s) like DIN V VDE 0801, IEC 61508 or EN 954-1. The hardware assessment consists of a FMEDA to determine the fault behavior and the failure rates of the device, which are then used to calculate the Safe Failure Fraction (SFF) and the average Probability of Failure on Demand (PFD<sub>AVG</sub>). In addition this option consists of an assessment of the proven-in-use documentation of the device and its software including the modification process.

This option for pre-existing programmable electronic devices shall provide the safety instrumentation engineer with the required failure data as per IEC 61508 / IEC 61511 and justify the reduced fault tolerance requirements of IEC 61511 for sensors, final elements and other PE field devices.

### Option 3: Full assessment according to IEC 61508

Option 3 is a full assessment by *exida.com* according to the relevant application standard(s) like IEC 61511 or EN 298 and the necessary functional safety standard(s) like DIN V VDE 0801, IEC 61508 or EN 954-1. The full assessment extends option 1 by an assessment of all fault avoidance and fault control measures during hardware and software development.

This option is most suitable for newly developed software based field devices and programmable controllers to demonstrate full compliance with IEC 61508 to the end-user.

### **This assessment shall be done according to option 1.**

This document shall describe the results of the hardware assessment carried out on the Isolating Switching Amplifiers IM1-\*\*(Ex)-\* and MK13-R-Ex0.

It shall be assessed whether the described devices meet the average Probability of Failure on Demand (PFD<sub>AVG</sub>) requirements and the architectural constraints for SIL 2 sub-systems according to IEC 61508.

It **does not** consider any calculations necessary for proving intrinsic safety.



## 2 Project management

### 2.1 exida.com

*exida.com* is one of the world's leading knowledge companies specializing in automation system safety and availability with over 100 years of cumulative experience in functional safety. Founded by several of the world's top reliability and safety experts from assessment organizations like TUV and manufacturers, *exida.com* is a partnership with offices around the world. *exida.com* offers training, coaching, project oriented consulting services, internet based safety engineering tools, detail product assurance and certification analysis and a collection of on-line safety and reliability resources. *exida.com* maintains a comprehensive failure rate and failure mode database on process equipment.

### 2.2 Roles of the parties involved

Werner Turck GmbH & Co. KG      Manufacturer of the considered Isolating Switching Amplifiers IM1-\*\*(Ex)-\* and MK13-R-Ex0.  
*exida.com*      Performed the hardware assessment according to option 1 (see section 1).

Werner Turck GmbH & Co. KG contracted *exida.com* in August 2004 with the FMEDA and PFD<sub>AVG</sub> calculation of the above mentioned device.

### 2.3 Standards / Literature used

The services delivered by *exida.com* were performed based on the following standards / literature.

[N1]	IEC 61508-2:2000	Functional Safety of Electrical/Electronic/Programmable Electronic Safety-Related Systems
[N2]	ISBN: 0471133019 John Wiley & Sons	Electronic Components: Selection and Application Guidelines by Victor Meeldijk
[N3]	FMD-91, RAC 1991	Failure Mode / Mechanism Distributions
[N4]	FMD-97, RAC 1997	Failure Mode / Mechanism Distributions
[N5]	NPRD-95, RAC	Non-electronic Parts – Reliability Data 1995
[N6]	SN 29500	Failure rates of components

### 2.4 Reference documents

#### 2.4.1 Documentation provided by the customer

[D1]	im1_22Ex0_R.pdf	Description of the working principle
[D2]	im1_22Ex0_T.pdf	Description of the working principle
[D3]	D201010.pdf	Data sheet Isolating switching amplifier IM1-12Ex-R 1-channel
[D4]	D201006.pdf	Data sheet Isolating switching amplifier IM1-12Ex-T 1-channel
[D5]	D201014.pdf	Data sheet Isolating switching amplifier IM1-22Ex-R 2-channel



# Decommissioning and withdrawal from service



[D6]	D201015.pdf	Data sheet Isolating switching amplifier IM1-22Ex-T 2-channel
[D7]	D201021.pdf	Data sheet Isolating switching amplifier IM1-121Ex-R 1-channel
[D8]	d201030.pdf	Data sheet Isolating switching amplifier IM1-121Ex-T 1-channel
[D9]	MK13_R_Ex0SL.pdf	Parts list 12296101 of 18.10.04
[D10]	MK13_R_Ex0Sch.pdf	Circuit diagram 12296100 of 07.10.04
[D11]	IM1_12ExRSL.pdf	Parts list 12296307 of 07.10.04
[D12]	IM1_12ExRSch.pdf	Circuit diagram 12296307 of 28.09.04
[D13]	IM1_12ExTSL.pdf	Parts list 12296309 of 07.10.04
[D14]	IM1_12ExTSch.pdf	Circuit diagram 12296309 of 28.09.04
[D15]	IM1_22ExRSL.pdf	Parts list 12296301 of 07.10.04
[D16]	IM1_22ExRSch.pdf	Circuit diagram 12296301 of 28.09.04
[D17]	IM1_22ExTSL.pdf	Parts list 12296303 of 13.08.04
[D18]	IM1_22ExTSch.pdf	Circuit diagram 12296303 of 28.09.04
[D19]	IM1_121Ex_R.pdf	Parts list 12296310 of 07.10.04
[D20]	IM1_121_ExRSch.pdf	Circuit diagram 12296310 of 28.09.04
[D21]	IM1_121Ex_T.pdf	Parts list 12296312 of 25.01.05
[D22]	IM1_121_TSch.pdf	Circuit diagram 12296312 of 28.09.04
[D23]	Manual.pdf	Manual of the ASIC
[D24]	SchaltungASIC.pdf	Circuit diagram of the ASIC
[D25]	LayoutASIC.pdf	Layout of the ASIC

## 2.4.2 Documentation generated by exida.com

[R1]	FMEDA V6 MK13-R-Ex0 V1 R1.0.xls of 11.03.05
[R2]	FMEDA V6 IM1-12Ex-R V1 R1.0.xls of 11.03.05
[R3]	FMEDA V6 IM1-12Ex-T V1 R1.0.xls of 11.03.05
[R4]	FMEDA V6 ASIC 5V regulator V0 R1.0.xls of 08.03.05
[R5]	FMEDA V6 ASIC 8V regulator V0 R1.0.xls of 07.03.05
[R6]	FMEDA V6 ASIC error signal path V0 R1.0.xls of 08.03.05
[R7]	FMEDA V6 ASIC NAMUR signal path detailed V0 R1.0.xls of 08.03.05
[R8]	FMEDA V6 ASIC PU block V0 R1.0.xls of 07.03.05
[R9]	FMEDA V6 ASIC remaining parts V0 R1.0.xls of 08.03.05
[R10]	FMEDA V6 ASIC partly detailed V0 R1.0.xls of 08.03.05
[R11]	Besprechung ASIC 07.03.05.txt

## 3 Description of the analyzed modules

The Isolating Switching Amplifiers IM1-\*\*(Ex)-\* and MK13-R-Ex0 consist of intrinsically safe input circuits.

They can be connected to sensors according to EN 60947-5-6 (NAMUR), variable resistors or potential-free contacts.

The output circuits, galvanically isolated from the input circuits, consist of either relay outputs or transistor outputs.

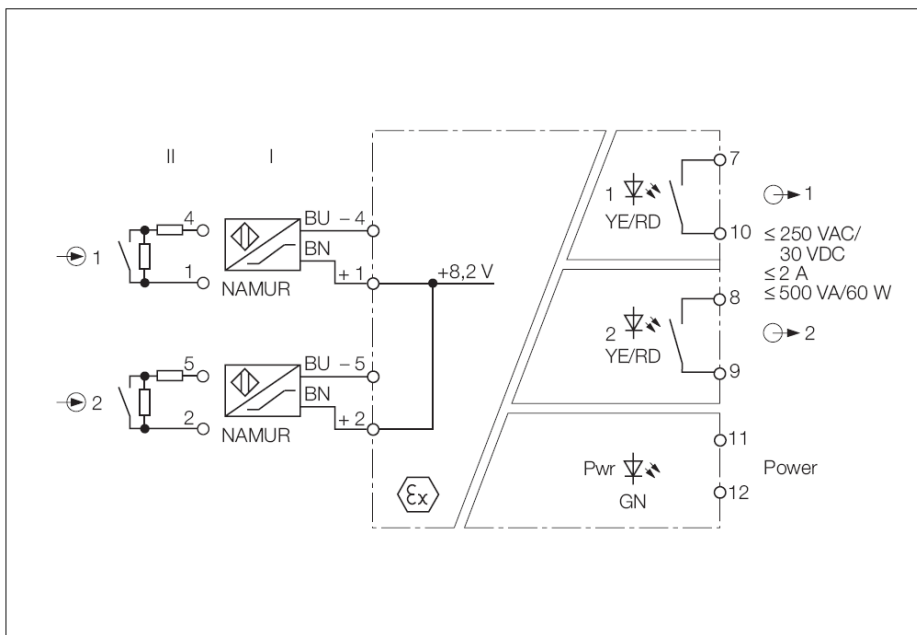

**Figure 1: Block diagram of the Isolating Switching Amplifier IM1-22Ex-R**

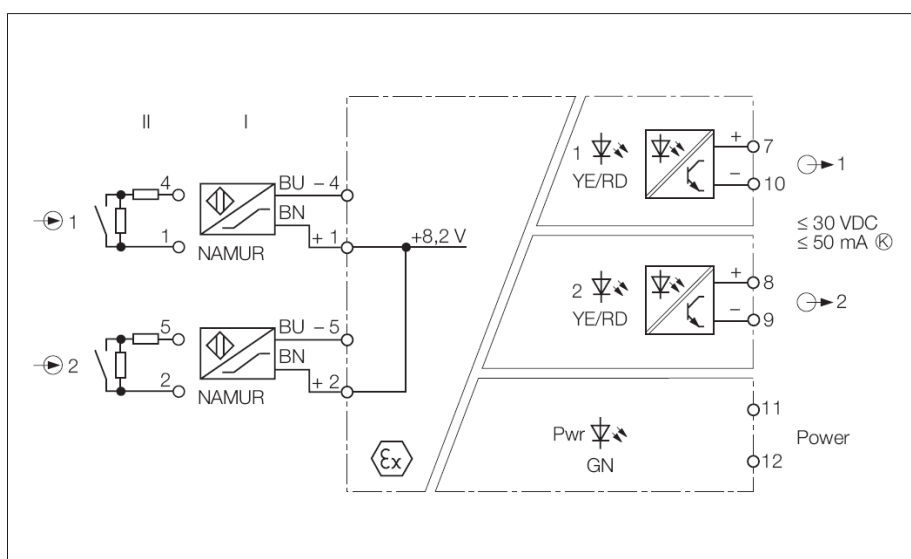

**Figure 2: Block diagram of the Isolating Switching Amplifier IM1-22Ex-T**



The block diagrams above show the working principal of all considered versions with the exception that the presented block diagrams have two input and two output channels. The differences between the versions are described in Table 1.

The Isolating Switching Amplifiers IM1-\*\*(Ex)-\* and MK13-R-Ex0 are considered to be Type A components with a hardware fault tolerance of 0.

Although the Isolating Switching Amplifiers IM1-\*\*(Ex)-\* and MK13-R-Ex0 are designed with a semi-custom ASIC 724 from ZETEX (see [D23]) they are still considered to be Type A components. The reason is the low complexity, the full analyzability of the used ASIC and the fact that the ASIC does not contain hidden state information such as internal digital registers (see [D24]). It only consists of 103 transistors, 908 resistors and 7 junction capacitors, which can individually be connected (see [D25]).

*exida.com* did a detailed analysis of the ASIC based on the individual failure modes of the internal transistors, resistors and capacitors (see [R4] to [R11]). Possible dependencies were taken into account with a common cause factor of 25%. The failure rate from the Siemens standard SN 29500 for a bipolar ECL ASIC with 50 to 5000 transistors was multiplied with a safety factor of 2. The resulting 100 FIT were used in the overall analysis for the Isolating Switching Amplifiers IM1-\*\*(Ex)-\* and MK13-R-Ex0.

## 4 Failure Modes, Effects, and Diagnostic Analysis

The Failure Modes, Effects, and Diagnostic Analysis was done together with Werner Turck GmbH & Co. KG and is documented in [R2] to [R10]. Failures can be classified according to the following failure categories.

### 4.1 Description of the failure categories

In order to judge the failure behavior of the Isolating Switching Amplifiers IM1-\*\*(Ex)-\* and MK13-R-Ex0, the following definitions for the failure of the product were considered.

Fail-Safe State	The fail-safe state is defined as the output being de-energized. This corresponds to an input signal of less than 1.4mA (NAMUR signal).
Fail Safe	Failure that causes the module / (sub)system to go to the defined fail-safe state without a demand from the process.
Fail Dangerous	Failure that does not respond to a demand from the process (i.e. being unable to go to the defined fail-safe state).
No Effect	Failure of a component that is part of the safety function but that has no effect on the safety function. For the calculation of the SFF it is treated like a safe undetected failure.
Not part	Failures of a component which is not part of the safety function but part of the circuit diagram and is listed for completeness. When calculating the SFF this failure mode is not taken into account. It is also not part of the total failure rate.

The “no effect” failures are provided for those who wish to do reliability modeling more detailed than required by IEC 61508. In IEC 61508 the “no effect” failures are defined as safe undetected failures even though they will not cause the safety function to go to a safe state. Therefore they need to be considered in the Safe Failure Fraction calculation.

### 4.2 Methodology – FMEDA, Failure rates

#### 4.2.1 FMEDA

A Failure Modes and Effects Analysis (FMEA) is a systematic way to identify and evaluate the effects of different component failure modes, to determine what could eliminate or reduce the chance of failure, and to document the system in consideration.

A FMEDA (Failure Modes, Effects, and Diagnostic Analysis) is a FMEA extension. It combines standard FMEA techniques with extension to identify online diagnostics techniques and the failure modes relevant to safety instrumented system design. It is a technique recommended to generate failure rates for each important category (safe detected, safe undetected, dangerous detected, dangerous undetected, fail high, fail low) in the safety models. The format for the FMEDA is an extension of the standard FMEA format from MIL STD 1629A, Failure Modes and Effects Analysis.



## 4.2.2 Failure rates

The failure rate data used by *exida.com* in this FMEDA are the basic failure rates from the Siemens SN 29500 failure rate database. The rates are considered to be appropriate for safety integrity level verification calculations. The rates match operating stress conditions typical of an industrial field environment similar to IEC 60654-1, class C. It is expected that the actual number of field failures will be less than the number predicted by these failure rates.

The user of these numbers is responsible for determining their applicability to any particular environment. Accurate plant specific data may be used for this purpose. If a user has data collected from a good proof test reporting system that indicates higher failure rates, the higher numbers shall be used. Some industrial plant sites have high levels of stress. Under those conditions the failure rate data is adjusted to a higher value to account for the specific conditions of the plant.

## 4.2.3 Assumptions

The following assumptions have been made during the Failure Modes, Effects, and Diagnostic Analysis of the Isolating Switching Amplifiers IM1-\*\*(Ex)-\* and MK13-R-Ex0.

- Failure rates are constant, wear out mechanisms are not included.
- Propagation of failures is not relevant.
- The time to restoration after a safe failure is 8 hours.
- All modules are operated in the low demand mode of operation.
- External power supply failure rates are not included.
- Only one input and one output are part of the safety function
- Sufficient tests are performed prior to shipment to verify the absence of vendor and/or manufacturing defects that prevent proper operation of specified functionality to product specifications or cause operation different from the design analyzed.
- The two channels on a redundant board are not used to increase the hardware fault tolerance needed for a higher SIL as they contain common components.
- The stress levels are average for an industrial environment and can be compared to the Ground Fixed classification of MIL-HNBK-217F. Alternatively, the assumed environment is similar to:
  - IEC 60654-1, Class C (sheltered location) with temperature limits within the manufacturer's rating and an average temperature over a long period of time of 40°C. Humidity levels are assumed within manufacturer's rating.

## 5 Results of the assessment

exida.com did the FMEDAs together with Werner Turck GmbH & Co. KG.

For the calculation of the Safe Failure Fraction (SFF) the following has to be noted:

$\lambda_{total}$  consists of the sum of all component failure rates. This means:

$$\lambda_{total} = \lambda_{safe} + \lambda_{dangerous} + \lambda_{no\ effect}$$

$$SFF = 1 - \lambda_{du} / \lambda_{total}$$

For the FMEDAs failure modes and distributions were used based on information gained from [N3] to [N5].

For the calculation of the  $PFD_{AVG}$  the following Markov model for 1oo1 system was used. As after a complete proof test all states are going back to the OK state no proof test rate is shown in the Markov models but included in the calculation.

The proof test time was changed using the Microsoft® Excel 2000 based FMEDA tool of exida.com as a simulation tool. The results are documented in the following sections.

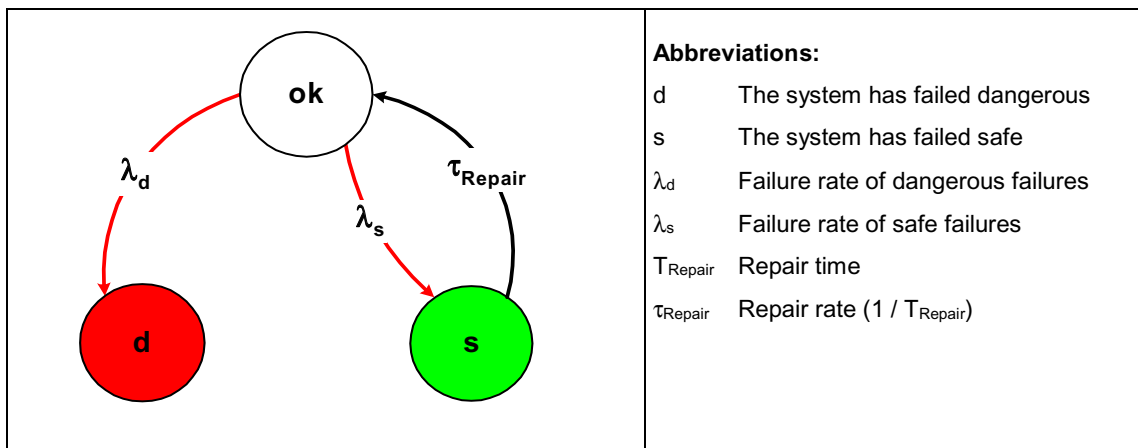

Figure 3: Markov model for a 1oo1 structure

### 5.1 Isolating Switching Amplifier MK13-R-Ex0

The FMEDA carried out on the Isolating Switching Amplifier MK13-R-Ex0 leads under the assumptions described in sections 4.2.3 and 5 to the following failure rates:

$$\lambda_{sd} = 0,00E-00 \text{ 1/h}$$

$$\lambda_{su} = 1,66E-07 \text{ 1/h}$$

$$\lambda_{dd} = 0,00E-00 \text{ 1/h}$$

$$\lambda_{du} = 1,10E-07 \text{ 1/h}$$

$$\lambda_{no \text{ effect}} = 1,22E-07 \text{ 1/h}$$

$$\lambda_{total} = 3,98E-07 \text{ 1/h}$$

$$\lambda_{not \text{ part}} = 1,04E-08 \text{ 1/h}$$

$$MTBF = MTTF + MTTR = 1 / (\lambda_{total} + \lambda_{not \text{ part}}) + 8 \text{ h} = 279 \text{ years}$$

Under the assumptions described in section 5 and the definitions given in section 4.1 the following table shows the failure rates according to IEC 61508:

$\lambda_{safe}$	$\lambda_{dangerous}$	SFF
288 FIT	110 FIT	72,44%

The  $PFD_{AVG}$  was calculated for three different proof test times using the Markov model as described in Figure 3.

T[Proof] = 1 year	T[Proof] = 5 years	T[Proof] = 10 years
$PFD_{AVG} = 4,80E-04$	$PFD_{AVG} = 2,40E-03$	$PFD_{AVG} = 4,79E-03$

The boxes marked in yellow (   ) mean that the calculated  $PFD_{AVG}$  values are within the allowed range for SIL 2 according to table 2 of IEC 61508-1 and table 3.1 of ANSI/ISA-84.01-1996 but do not fulfill the requirement to not claim more than 10% of this range, i.e. to be better than or equal to  $1,00E-03$ . The boxes marked in green (   ) mean that the calculated  $PFD_{AVG}$  values are within the allowed range for SIL 2 according to table 2 of IEC 61508-1 and table 3.1 of ANSI/ISA-84.01-1996 and do fulfill the requirement to not claim more than 10% of this range, i.e. to be better than or equal to  $1,00E-03$ . Figure 4 shows the time dependent curve of  $PFD_{AVG}$ .

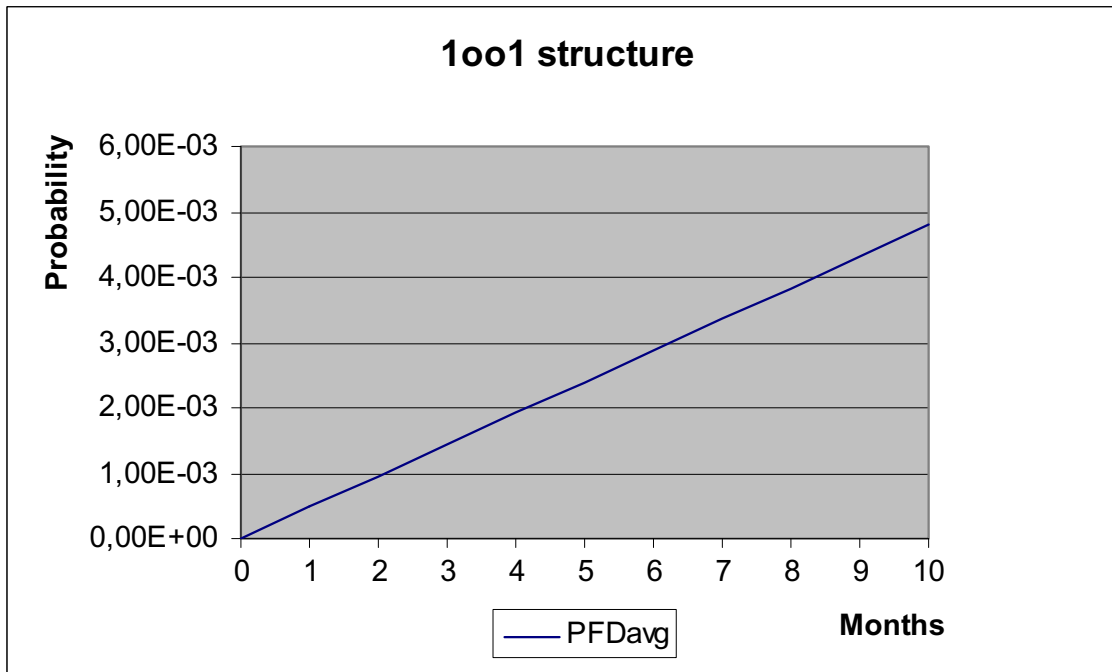

Figure 4: PFD<sub>AVG</sub>(t)



## 5.2 Isolating Switching Amplifier IM1-\*\*\*-R

The FMEDA carried out on the Isolating Switching Amplifier IM1-\*\*\*-R leads under the assumptions described in sections 4.2.3 and 5 to the following failure rates:

$$\lambda_{sd} = 0,00E-00 \text{ 1/h}$$

$$\lambda_{su} = 1,72E-07 \text{ 1/h}$$

$$\lambda_{dd} = 0,00E-00 \text{ 1/h}$$

$$\lambda_{du} = 1,10E-07 \text{ 1/h}$$

$$\lambda_{no \text{ effect}} = 1,27E-07 \text{ 1/h}$$

$$\lambda_{total} = 4,09E-07 \text{ 1/h}$$

$$\lambda_{not \text{ part}} = 1,10E-08 \text{ 1/h}$$

$$MTBF = MTTF + MTTR = 1 / (\lambda_{total} + \lambda_{not \text{ part}}) + 8 \text{ h} = 272 \text{ years}$$

Under the assumptions described in section 5 and the definitions given in section 4.1 the following table shows the failure rates according to IEC 61508:

$\lambda_{safe}$	$\lambda_{dangerous}$	SFF
299 FIT	110 FIT	73,15%

The  $PFD_{AVG}$  was calculated for three different proof test times using the Markov model as described in Figure 3.

T[Proof] = 1 year	T[Proof] = 5 years	T[Proof] = 10 years
$PFD_{AVG} = 4,80E-04$	$PFD_{AVG} = 2,40E-03$	$PFD_{AVG} = 4,79E-03$

The boxes marked in yellow (   ) mean that the calculated  $PFD_{AVG}$  values are within the allowed range for SIL 2 according to table 2 of IEC 61508-1 and table 3.1 of ANSI/ISA-84.01-1996 but do not fulfill the requirement to not claim more than 10% of this range, i.e. to be better than or equal to  $1,00E-03$ . The boxes marked in green (   ) mean that the calculated  $PFD_{AVG}$  values are within the allowed range for SIL 2 according to table 2 of IEC 61508-1 and table 3.1 of ANSI/ISA-84.01-1996 and do fulfill the requirement to not claim more than 10% of this range, i.e. to be better than or equal to  $1,00E-03$ . Figure 5 shows the time dependent curve of  $PFD_{AVG}$ .

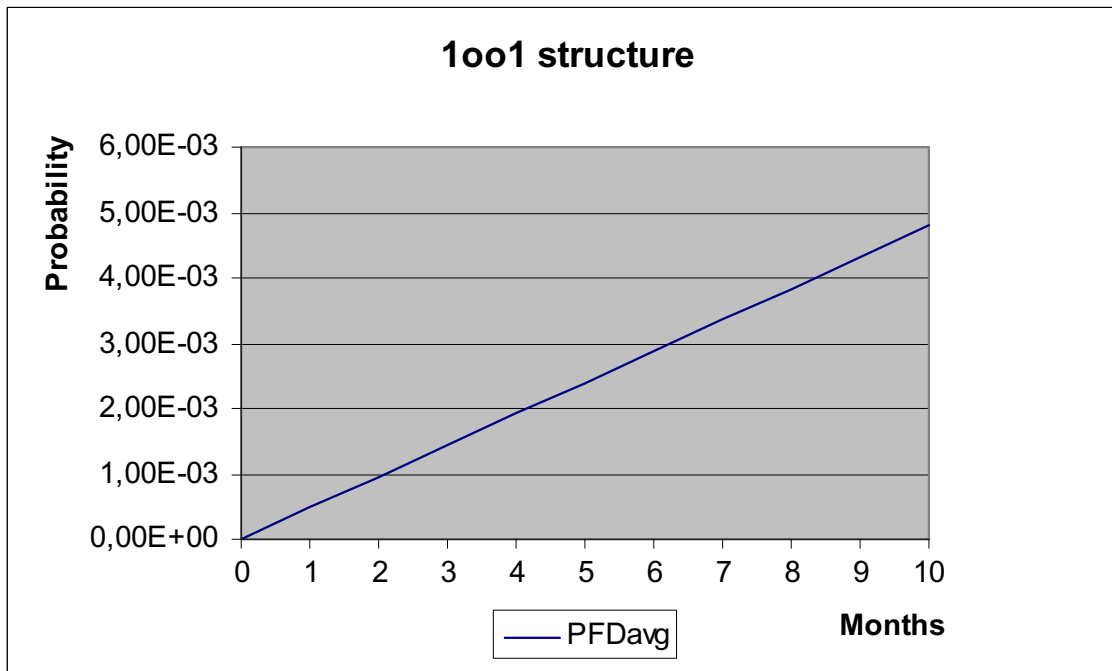

Figure 5: PFD<sub>AVG</sub>(t)

### 5.3 Isolating Switching Amplifier IM1-\*\*\*-T

The FMEDA carried out on the Isolating Switching Amplifier IM1-\*\*\*-T leads under the assumptions described in sections 4.2.3 and 5 to the following failure rates:

$$\lambda_{sd} = 0,00E-00 \text{ 1/h}$$

$$\lambda_{su} = 1,44E-07 \text{ 1/h}$$

$$\lambda_{dd} = 0,00E-00 \text{ 1/h}$$

$$\lambda_{du} = 8,49E-08 \text{ 1/h}$$

$$\lambda_{no \text{ effect}} = 1,23E-07 \text{ 1/h}$$

$$\lambda_{total} = 3,52E-07 \text{ 1/h}$$

$$\lambda_{not \text{ part}} = 1,10E-08 \text{ 1/h}$$

$$MTBF = MTTF + MTTR = 1 / (\lambda_{total} + \lambda_{not \text{ part}}) + 8 \text{ h} = 314 \text{ years}$$

Under the assumptions described in section 5 and the definitions given in section 4.1 the following table shows the failure rates according to IEC 61508:

$\lambda_{safe}$	$\lambda_{dangerous}$	SFF
267 FIT	85 FIT	75,89%

The  $PFD_{AVG}$  was calculated for three different proof test times using the Markov model as described in Figure 3.

T[Proof] = 1 year	T[Proof] = 5 years	T[Proof] = 10 years
$PFD_{AVG} = 3,72E-04$	$PFD_{AVG} = 1,86E-03$	$PFD_{AVG} = 3,71E-03$

The boxes marked in yellow (   ) mean that the calculated  $PFD_{AVG}$  values are within the allowed range for SIL 2 according to table 2 of IEC 61508-1 and table 3.1 of ANSI/ISA-84.01-1996 but do not fulfill the requirement to not claim more than 10% of this range, i.e. to be better than or equal to  $1,00E-03$ . The boxes marked in green (   ) mean that the calculated  $PFD_{AVG}$  values are within the allowed range for SIL 2 according to table 2 of IEC 61508-1 and table 3.1 of ANSI/ISA-84.01-1996 and do fulfill the requirement to not claim more than 10% of this range, i.e. to be better than or equal to  $1,00E-03$ . Figure 6 shows the time dependent curve of  $PFD_{AVG}$ .

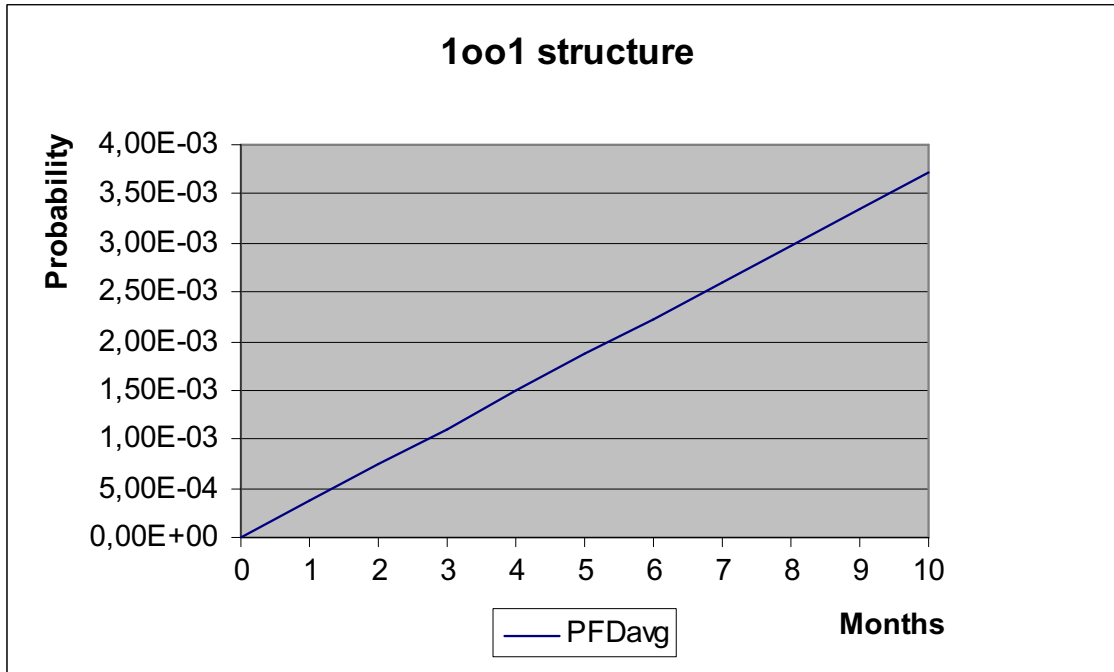

Figure 6: PFD<sub>AVG</sub>(t)



## 6 Terms and Definitions

FIT	Failure In Time ( $1 \times 10^{-9}$ failures per hour)
FMEDA	Failure Modes, Effects, and Diagnostic Analysis
HFT	Hardware Fault Tolerance
Low demand mode	Mode, where the frequency of demands for operation made on a safety-related system is no greater than one per year and no greater than twice the proof test frequency.
$PFD_{AVG}$	Average Probability of Failure on Demand
SFF	Safe Failure Fraction summarizes the fraction of failures, which lead to a safe state and the fraction of failures which will be detected by diagnostic measures and lead to a defined safety action.
SIF	Safety Instrumented Function
SIL	Safety Integrity Level
Type A component	"Non-complex" component (all failure modes are well defined); for details see 7.4.3.1.2 of IEC 61508-2.
T[Proof]	Proof Test Interval

## 7 Status of the document

### 7.1 Liability

*exida* prepares reports based on methods advocated in International standards. Failure rates are obtained from a collection of industrial databases. *exida* accepts no liability whatsoever for the use of these numbers or for the correctness of the standards on which the general calculation methods are based.

Due to future potential changes in the standards, best available information and best practices, the current FMEDA results presented in this report may not be fully consistent with results that would be presented for the identical product at some future time. As a leader in the functional safety market place, *exida* is actively involved in evolving best practices prior to official release of updated standards so that our reports effectively anticipate any known changes. In addition, most changes are anticipated to be incremental in nature and results reported within the previous three year period should be sufficient for current usage without significant question.

Most products also tend to undergo incremental changes over time. If an *exida* FMEDA has not been updated within the last three years and the exact results are critical to the SIL verification you may wish to contact the product vendor to verify the current validity of the results.

### 7.2 Releases

Version History: V3R0: IM1-12-R, IM1-12-T and IM1-22-T added; February 21, 2014  
V2R0: IM1-22-R added; February 8, 2013  
V1, R1.0: External review comments integrated; April 14, 2005  
V0, R2.0: Internal review comments integrated; March 31, 2005  
V0, R1.0: Initial version; March 11, 2005

Authors: Stephan Aschenbrenner

Review: V0, R1.0: Rachel Amkreutz (*exida.com*); March 28, 2005

V0, R2.0: Frank Seeler (Werner Turck GmbH & Co. KG); April 13, 2005

Release status: Released to Werner Turck GmbH & Co. KG

### 7.3 Release Signatures

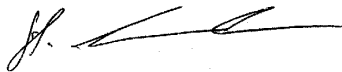

---

Dipl.-Ing. (Univ.) Stephan Aschenbrenner, Partner



---

Dipl.-Ing. (Univ.) Rainer Faller, Principal Partner

## Appendix 1: Possibilities to reveal dangerous undetected faults during the proof test

According to section 7.4.3.2.2 f) of IEC 61508-2 proof tests shall be undertaken to reveal dangerous faults which are undetected by diagnostic tests.

This means that it is necessary to specify how dangerous undetected faults which have been noted during the FMEDA can be detected during proof testing.

Table 8, Table 9 and Table 10 show an importance analysis of the most critical dangerous undetected faults and indicate how these faults can be detected during proof testing.

Appendix 1 shall be considered when writing the safety manual as it contains important safety related information.

**Table 8: Importance Analysis of dangerous undetected faults of MK13-R-Ex0**

Component	% of total $\lambda_{du}$	Detection through
IC3	60,90%	100% functional test with monitoring of the expected output signal
K1	22,78%	100% functional test with monitoring of the expected output signal
T101	10,03%	100% functional test with monitoring of the expected output signal
IC1	4,10%	100% functional test with monitoring of the expected output signal
D101	0,91%	100% functional test with monitoring of the expected output signal
C101	0,91%	100% functional test with monitoring of the expected output signal
X4	0,18%	100% functional test with monitoring of the expected output signal
R101	0,18%	100% functional test with monitoring of the expected output signal

**Table 9: Importance Analysis of dangerous undetected faults of IM1-\*\*\*-R**

Component	% of total $\lambda_{du}$	Detection through
IC4	60,90%	100% functional test with monitoring of the expected output signal
K1	22,78%	100% functional test with monitoring of the expected output signal
T102	10,03%	100% functional test with monitoring of the expected output signal
IC1	4,10%	100% functional test with monitoring of the expected output signal
D100	0,91%	100% functional test with monitoring of the expected output signal
C100	0,91%	100% functional test with monitoring of the expected output signal
X1	0,18%	100% functional test with monitoring of the expected output signal
R100	0,18%	100% functional test with monitoring of the expected output signal





**Table 10: Importance Analysis of dangerous undetected faults of IM1-\*\*\*-T**

Component	% of total $\lambda_{du}$	Detection through
IC4	78,73%	100% functional test with monitoring of the expected output signal
T202	12,96%	100% functional test with monitoring of the expected output signal
IC2	5,30%	100% functional test with monitoring of the expected output signal
D100	1,18%	100% functional test with monitoring of the expected output signal
C100	1,18%	100% functional test with monitoring of the expected output signal
X1	0,24%	100% functional test with monitoring of the expected output signal
R100	0,24%	100% functional test with monitoring of the expected output signal
D203	0,18%	100% functional test with monitoring of the expected output signal



## Appendix 1.1: Possible proof tests to detect dangerous undetected faults

The proof test consists of the following steps, as described in Table 11.

**Table 11 Steps for Proof Test**

Step	Action
1	Take appropriate action to avoid a false trip
2	Provide NAMUR control signals to the Isolating Switching Amplifier to open/close the output and verify that the output is open/closed.
3	Restore the loop to full operation
4	Restore normal operation

This test will detect more than 90% of possible “du” failures of the Isolating Switching Amplifier.



## Appendix 2: Impact of lifetime of critical components on the failure rate

Although a constant failure rate is assumed by the probabilistic estimation method (see section 4.2.3) this only applies provided that the useful lifetime of components is not exceeded. Beyond their useful lifetime, the result of the probabilistic calculation method is meaningless, as the probability of failure significantly increases with time. The useful lifetime is highly dependent on the component itself and its operating conditions – temperature in particular (for example, electrolyte capacitors can be very sensitive).

This assumption of a constant failure rate is based on the bathtub curve, which shows the typical behavior for electronic components.

Therefore it is obvious that the  $PFD_{AVG}$  calculation is only valid for components which have this constant domain and that the validity of the calculation is limited to the useful lifetime of each component.

It is assumed that early failures are detected to a huge percentage during the installation period and therefore the assumption of a constant failure rate during the useful lifetime is valid.

The circuits of the Isolating Switching Amplifiers IM1-\*\*(Ex)-\* and MK13-R-Ex0 do not contain any electrolytic capacitors or other components that are contributing to the dangerous undetected failure rate. Therefore there is no limiting factor with regard to the useful lifetime of the system.

However, according to section 7.4.7.4 of IEC 61508-2, a useful lifetime, based on experience, should be assumed. According to section 7.4.7.4 note 3 of IEC 61508-2 experience has shown that the useful lifetime often lies within a range of 8 to 12 years.

**TURCK**

**Industrial  
Automation**



**www.turck.com**

**Your Global  
Automation Partner!**

**WORLDWIDE HEADQUARTERS**

Hans Turck GmbH & Co. KG  
Witzlebenstr. 7  
45472 Muelheim an der Ruhr  
Germany  
Tel. +49 208 4952-0  
Fax +49 208 4952-264  
E-Mail [more@turck.com](mailto:more@turck.com)  
Internet [www.turck.com](http://www.turck.com)

D201457 2014/11

